

Innovative **ideas** reduce maintenance to minutes and boost filter efficiency

Boost filter life and efficiency with our reverse-pulse jet filter cleaner.

Reduce filter changes to minutes using the side-access door, always standard on Hapman MiniVac™ conveyors.

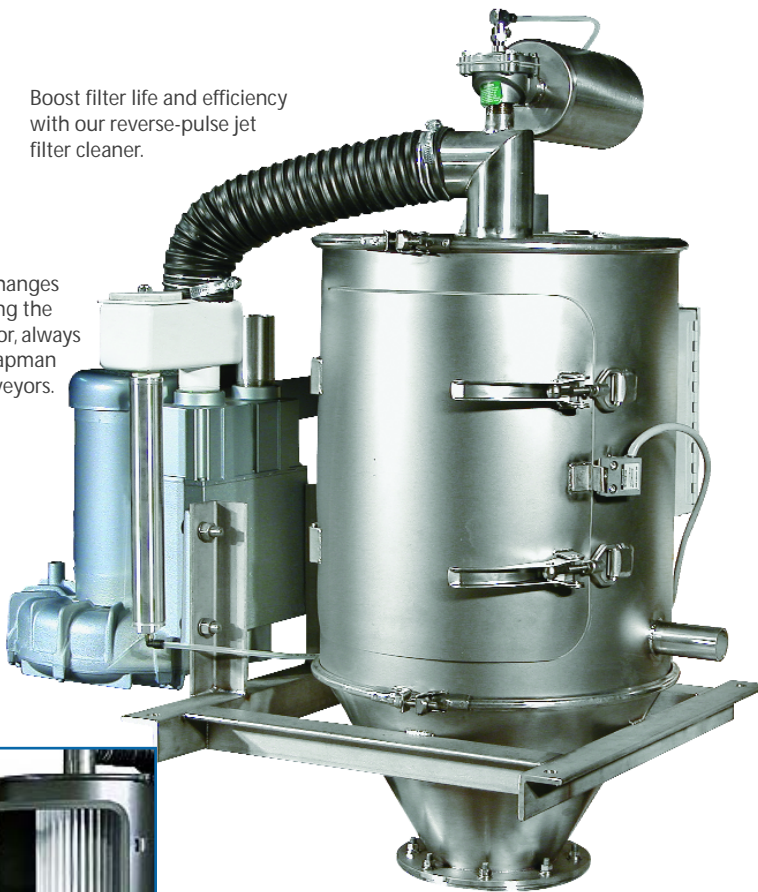

> **Eliminates the need for an expensive air supply.** The MiniVac™ comes complete with an integral blower, eliminating the need for expensive plant air or a separate compressor.

> **Increases operating efficiency.** HAPMAN's regenerative blower provides the highest in conveying efficiency.

> **Lengthens filter life and maximizes performance.** The MiniVac™ has a standard reverse-pulse jet filter cleaning system that keeps the filter clean and at optimum operating efficiency.

> **Allows easy filter replacement.** The standard side-access door lets you replace the filter in less than 5 minutes - no tools required.

> **Offers simple in-plant installation.** The compact and integral blower (eliminating the need for air piping) makes installation easy.

> **Clean the unit easily,** especially when changing over to a new material. Fully discharges material; reverse-pulse filter cleaner ensures no material is left behind.

> **Meet your specific requirements.** HAPMAN'S flexibility in engineering capacity and designs - even portable units - ensure your needs are met exactly.

> **Know your system will function properly** through FREE product testing in our lab, which analyzes your material at your rates.

"They listened ... and we got a system that fit our special needs."

You face your own frustrating challenges moving powder bulk solids, whether it's spilled, lost or damaged product or conveying along unusual paths.

Challenges that cookie-cutter approaches won't solve and that take time you don't have.

Drawing on decades of experience, we bring you ideas for the most efficient, reliable way to move your bulk materials in your particular circumstances—now and in the future. Our friendly, flexible staff responds quickly to keep you moving and makes getting the right system easy.

**More efficient material handling. More product kept intact.
More answers to meet your special needs. That's Ideas that move.**

HAPMAN

Ideas that move.

effective

Solutions



Conveyor Paths

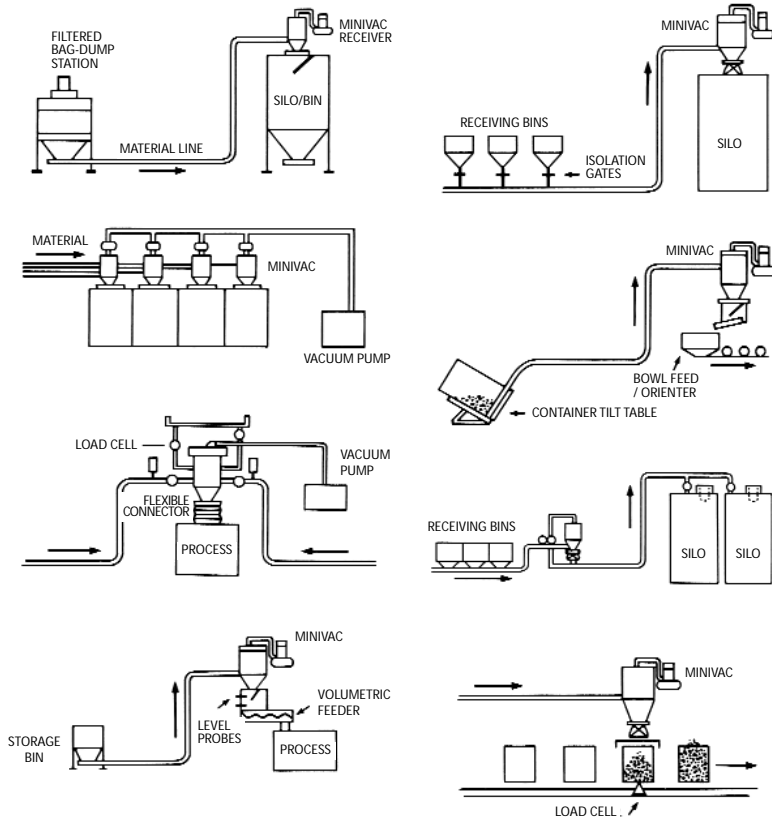

Conveyor Capacities

MODEL	16D	16R	20D	20R	24D	24R
FILTER AREA (SQ. FT.)	13	13	13	13	31	31
BLOWER SIZE (HP)	1 1/2	1 1/2	2-1/2	2-1/2	5	5
BLOWER CAP. (CFM)	60	60	100	100	150	150
COMPRESSED AIR REQ. (PSI)	60	60	60	60	80	80
Capacity (lbs/hour)	800	1,200	2,000	2,500	4,000	5,000

Note: Specifications subject to change without notice- Contact a factory sales engineer for specifications and options.

*Nominal capacity based upon 75ft. equivalent length piping.

**Larger blower sizes and configurations available.

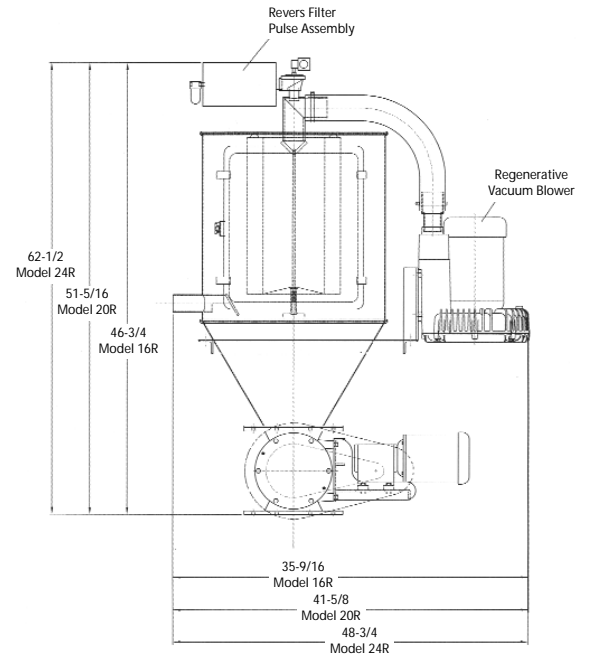
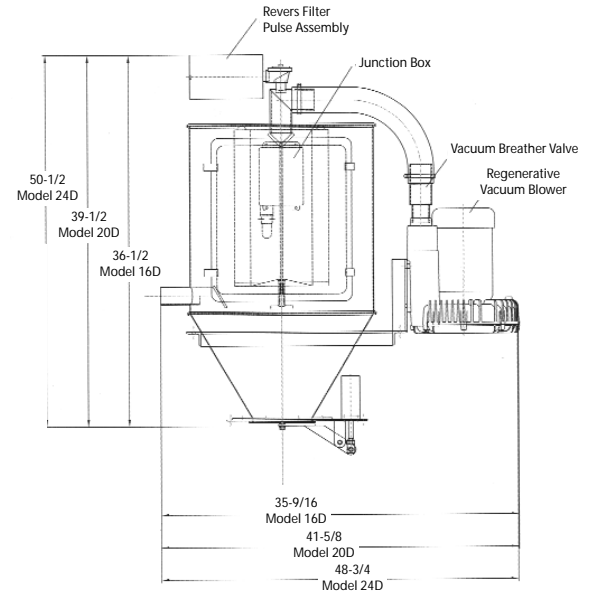

HAPMAN

Ideas that move.

	6002 E. Kilgore Rd. Kalamazoo, MI 49048-2321 U.S.A.
	269.343.1675 800.427.6260 Fax 269.349.2477
	www.hapman.com sales@hapman.com