



PHX-150

DRY ICE CLEANING SYSTEM

The Safe, Clean, Effective Dry Ice Blasting Solution

The Phoenix PHX-150 delivers powerful dry ice blasting capabilities in a mobile, economical, highly efficient unit.

- ❁ Reinforced stainless steel construction with high-capacity dry ice pellet hopper
- ❁ Powerful, reliable airlock provides effective cleaning for all types of applications
- ❁ All pneumatic, single-hose design for superior performance and flexibility
- ❁ Capable of blasting pellet and granule media at a fraction of the cost of granule only machines
- ❁ Adjustable blast pressure and ice rates offer enhanced performance over a wide range of applications
- ❁ Built-in separator/filter provides added protection of the pneumatic controls and helps clean the blast air



Dry Ice Blasting is Environmentally Friendly

Most dry ice is made from recaptured or reclaimed carbon dioxide being emitted by industrial processes. Dry ice cleaning reduces and in some cases eliminates the need for hazardous cleaning chemicals. The dry ice particles disappear on impact resulting in significant reductions in the amount of hazardous waste being generated.



**This dry ice blasting system uses
HIGH DENSITY DRY ICE PELLETS**

PHX-150

SPECIFICATIONS

Dimensions:	18" x 20" x 47" (W x L x H) (36cm x 43cm x 116cm)
Dry Weight:	140 Lbs (63 kg)
Hopper Capacity:	Over 100 lbs (45.5 kg) of pellets
Ice Consumption Range:	0.5-5 lbs (0.23kg - 2.3kg)/min
Supply Air Pressure:	70 psi - 125 psi (4.8 - 8.6 bar)
Air Consumption Range:	100 CFM to 250 CFM
Blast Pressure Range:	50 psi - 125 psi (2.8 - 8.6 bar)
Inlet Air Temperature:	140° F (60° C) maximum
Inlet Air Connection:	1" FNPT

Quick Air Hose Connection

Convenient front hook-up with a single blast hose that is easily maneuvered.

Ergonomic Controls

The angled control panel with easy-to-understand controls provides easy viewing and accessibility.

Dry Ice Capacity

Large hopper capacity is fast loading and eliminates frequent refilling.

Safety Interlocks and Guards

The safety interlock and guards prevent accidental contact with any moving parts. 100% pneumatic operation eliminates electrical shock hazards.

Navigates Easily

18" Wide body easily fits through tight doorways and tight spaces. The unit is lightweight and the large rubber tires negotiate rough surfaces.

Durable Construction

Reinforced stainless steel construction and molded rubber casters are very durable. Unit is operational in any weather environment.

Quick Release Airlock

The quick-release airlock makes for faster cleaning and inspection.

Minimal Maintenance

Built-in separator/filter for added protection. Easy access to components - reduced downtime for periodic maintenance.

Customer Service

Technical assistance is available 24/7 year round.

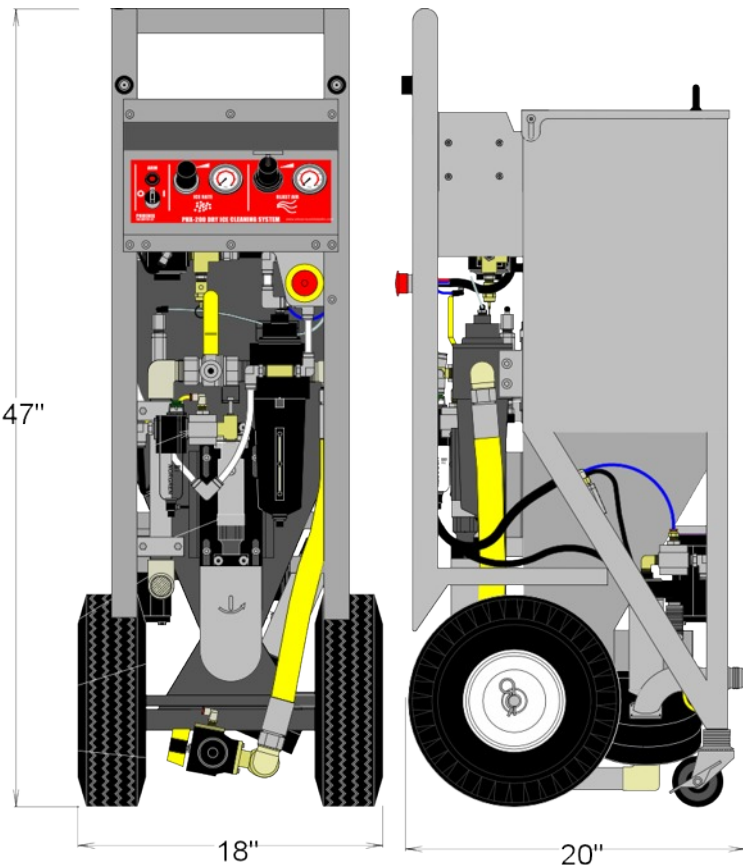

The PHX-150 comes with the Phoenix 24" Standard nozzle and 25' of blast hose.

Additional nozzles include fan, tube nozzles, round nozzles and a pellet fragmenter.

Authorized Distributor:



310 North Cota Street, Suite H
Corona, CA 92880

Tel: 951.278.2229

Fax 951.278.0084

www.phoenixunlimitedllc.com